



**Hangcha Europe GmbH**

Mariechen-Graulich-Straße 12a,  
65439 Flörsheim am Main,  
Germany

Tel: 0049-61453769188  
E-mail: admin@hangchaeurope.com

Mob: 0049-16096548808 (Thomas Dittrich)  
E-mail: thomas.dittrich@hangchaeurope.com  
Zip Code Area (1,2,3,4,5,6,7)

Mob: 0049-1605272481 (Jens Aßmuth)  
E-mail: jens.assmuth@hangchaeurope.com  
Zip Code Area (0,8,9)

[www.hangchaeurope.com](http://www.hangchaeurope.com)



Follow us on  
Instagram



Follow us on  
Facebook



Follow us on  
YouTube



Download "Hangcha  
Forklift" App



ISO14001:2015



ISO9001:2015



HANGCHA trucks conform  
to the European Safety  
Requirements.

2021 VERSION 1/COPYRIGHT 2021/09

HANGCHA GROUP CO., LTD. reserves the right to make any changes without notice concerning colors, equipment, or specifications detailed in this brochure, or to discontinue individual models. The colors of trucks, delivered may differ slightly from those in brochures.



## A series Electric Tow Tractor

with capacities of 2,000 to 6,000kg

*The World of Hangcha*





# LET THE LITHIUM POWER FREED



## INNOVATIVE SOLUTIONS NEW POWER NOW

Innovative, reliable lithium-ion technology (Lithium Iron-Phosphate), which are developed jointly by HANGCHA and CATL. Battery cells and modules are from CATL, with reliable quality, exclusively for HANGCHA.

- / We use square lithium iron phosphate batteries and modules used in large quantities by commercial vehicles in mature economies.
- / The module uses an aluminum alloy frame which is sturdy, lightweight and with excellent heat dissipation.
- / Safe and effective: Charging efficiency as high as 98%, thermal runaway temperature 600 °C or above.
- / Adapted to low temperatures: Comes standard with an electrical heating feature, ensuring normal operation in low temperatures.
- / Quick charging: Can charge and operate at the same time, fully charged in 2 hours.
- / Long-working: 4000 charging cycles, capacity retention greater than 80%.
- / Maintenance-free: Battery does not require manual maintenance.
- / Green and clean: Pollution-free, zero emissions.

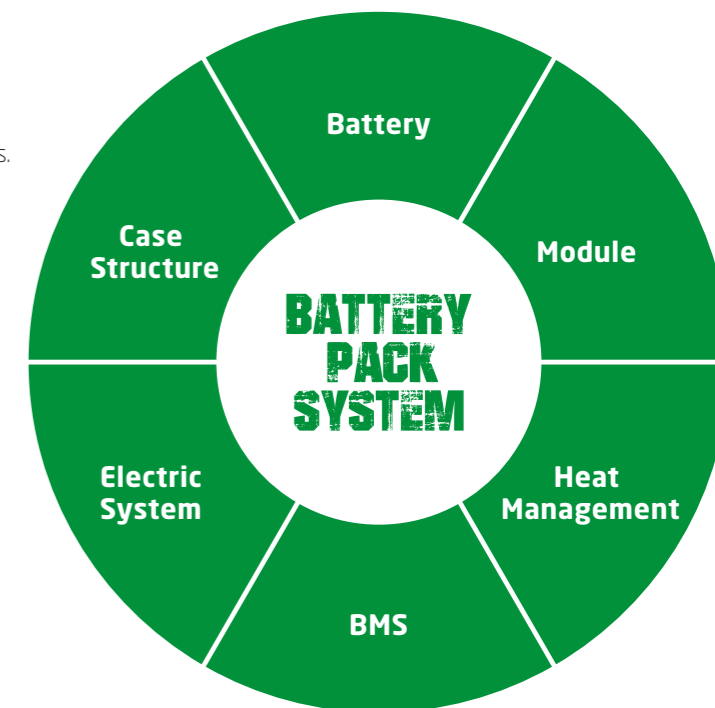

Li-Ion  
2 hours  
100%

Lead-acid batteries  
8-10 hours 100%

**Rapid charging and opportunity charging ensure continuous availability of vehicles.**

Li-Ion powered forklifts are always available. They allow for fast full charging or boost charging (100 % charge in 2 hours). They are maintenance free and do not require a battery change when used for multi-shift operations.

### Li-Ion Battery Pack specification

Type		QDD40-AC1-I	QDD40-AC1S-I	QDD60-AC1-I	QDD60-AC1S-I
Li-Ion battery	V/Ah	48/202	48/202	48/202	48/202
Titans charger		SLC-48100	SLC-48100	SLC-48100	SLC-48100



HANGCHA provides Li-Ion battery (LiFePO4) with 5 years or 10000 hours warranty.



**5 YEARS  
WARRANTY**



# A series Electric Tow Tractor

As for A series of tractors, the advanced AC drive control technology is adopted for the complete tractor. The tractor has excellent performance, can be operated comfortably, is safe and reliable, has low maintenance cost and is the high-efficiency tool for resolving material transport among different zones for the workshops, flow lines and large factories.

**Simple/  
Solid/  
Smart**



## Appearance

- / The professional appearance industrial design is adopted. The complete tractor has smooth lines, presents the dynamics. The ergonomics is fully considered to meet the latest appearance design fashion.
- / The steel plate stamping and injection moulding technology is used extensively, the tractor is firm and durable and can meet the environmental protection requirements.

## High performance

- / For the stand-up driving tractor, the electronic power steering is taken as the standard configuration to achieve easier and more flexible operation and control.
- / The AC traction motor features excellent acceleration performance, outstanding climbing ability, low heat emission, and is brushless, and maintenance-free.
- / The advanced AC control system realizes accurate and stable control, and higher efficiency.
- / The CANBUS bus structure makes communication of the entire machine faster and more reliable.

## Comfortability

- / LED headlight is taken as the standard configuration; the headlight has good appearance and offers bright light.
- / Multifunctional instrument is taken as the standard configuration, has such many functions as speed selection and so on, and can clearly display different information of the tractor.
- / The suspension structure is adopted for the front axle and rear axle to greatly enhance the operator's comfortability during tractor traveling.
- / USB charging port and mobile phone placement slot are taken as the standard configuration for conveniently charging the mobile phone and providing convenience for the operator.
- / The advancing and retreating buttons are provided at the tail of the tractor body, so that the tractor can be operated to move forward and backward while manipulating the traction device and it does not need to frequently go aboard and get off during operation.



Reliable LED lighting



Battery side roll out is taken as the standard configuration in order to easily and fast replace the battery



Modern outline design with LCD instrument and USB charging port



Electrical Park Brake (EPB) system



The locking device of the battery is provided with the safety protection function. Only if the locking device is rotated in place, the tractor can travel





## A series Electric Tow Tractor specification

Distinguishing mark	1.1	HANGCHA GROUP CO.,LTD.						
		QDD20-AC1 QDD20-AD2	QDD20-AC1S QDD20-AD2S	QDD40-AC1 QDD40-AD2	QDD40-AC1S QDD40-AD2S	QDD60-AC1 QDD60-AD2	QDD60-AC1S QDD60-AD2S	
1.2	Manufacturer's type designation							
1.3	Drive: electric (battery or mains), diesel, petrol, fuel gas	Electric	Electric	Electric	Electric	Electric	Electric	
1.4	Operator type: hand, pedestrian, standing, seated, order-picker	Seated	Standing	Seated	Standing	Seated	Standing	
1.5	Rated capacity/rated load	Q(t)	2	2	4	4	6	
1.7	Rated drawbar pull	F(N)	500	500	1000	1000	1500	
1.9	Wheelbase	y(mm)	1145	1145	1305	1305	1305	
Weights	2.1	Service Weight (Including battery)	kg	880	880	1080	1080	1150
Wheels,Tyres	3.1	Tyres: solid rubber, superelastic, pneumatic, polyurethane		Pneumatic	Pneumatic	Pneumatic	Pneumatic	Pneumatic
	3.2	Tyre size, front		3.50-5-6PR	3.50-5-6PR	3.50-5-6PR	3.50-5-6PR	3.50-5-6PR
	3.3	Tyre size, rear		4.00-8-6PR	4.00-8-6PR	4.00-8-6PR	4.00-8-6PR	4.00-8-6PR
	3.5	Wheels, number front / rear (x = driven wheels)		1/2x	1/2x	2/2x	2/2x	2/2x
	3.6	Tread, front	b <sub>10</sub> (mm)	0	0	250	250	250
	3.7	Tread, rear	b <sub>11</sub> (mm)	770	770	770	770	770
	4.1.2	Coupling height	h <sub>10</sub> (mm)	365/267	365/267	365/267	365/267	365/267
	4.1.7	Overhang	l <sub>s</sub> (mm)	245	245	245	245	245
	4.1.9	Overall length	l <sub>t</sub> (mm)	1684	1684	1844	1844	1844
	4.2.1	Overall width	b <sub>1</sub> (mm)	900	900	900	900	900
	4.3.2	Ground clearance, centre of wheelbase	m <sub>z</sub> (mm)	100	100	100	100	100
	4.3.5	Turning radius	W <sub>a</sub> (mm)	1600	1600	1763	1763	1763
Performance	5.1	Travel speed, laden/unladen	km/h	6/13	6/13	6/13	6/13	6/13
	5.6	Max. Drawbar pull	N	2000	2000	4000	4000	4500
	5.7	Gradeability, laden/unladen	%	5/25	5/25	5/25	5/25	5/25
Electric engine	6.1	Drive motor rating S2 60 min	kW	1.95	1.95	4.28	4.28	4.28
	6.2	Type of drive motor		AC	AC	AC	AC	AC
	6.4	Battery voltage, nominal capacity K5,Standard	V/Ah	48/165	48/165	48/210	48/210	48/275
		Battery voltage, nominal capacity K5,Optional	V/Ah	48/180-210	48/180-210	48/220-350	48/220-350	48/280-350
		Controller		CURTIS INMOTION	CURTIS INMOTION	CURTIS INMOTION	CURTIS INMOTION	CURTIS INMOTION

## Reliability

- / The three-support-point and low-gravity-center design is adopted. The high-strength steel plate framed structure is adopted for the chassis. The tractor has long service life.
- / All of wires and cables are provided with reliable protection, and the electrical system reliability is greatly improved.
- / Such important components as switches, connector clips, instruments and so on are imported from foreign countries, and have excellent performance and reliable quality.

## Safety

- / Turning slow down function is taken as the standard configuration to guarantee stable and safe turning of the tractor.
- / The Electrical Park Brake (EPB) is taken as standard configuration to achieve greater convenience and safety.
- / The safety pedal is taken as standard configuration. The other operations can be made only if the pedal is trampled. In this way, safety is enhanced.

## Standard specification

- / AC traction motor
- / Automatic deceleration at turns
- / Key switch
- / USB charging port
- / LED headlight
- / LED tail light
- / Battery side roll out
- / Creep speed function
- / Safety pedal (for seating driving type tractor)
- / Emergency power-off switch
- / Electrical Park Brake (EPB) system
- / Traction device
- / Electrostatic conductive belt
- / Horn
- / Toolbox
- / Inching switch



Electronic power steering system (for stand-up driving type tractor)

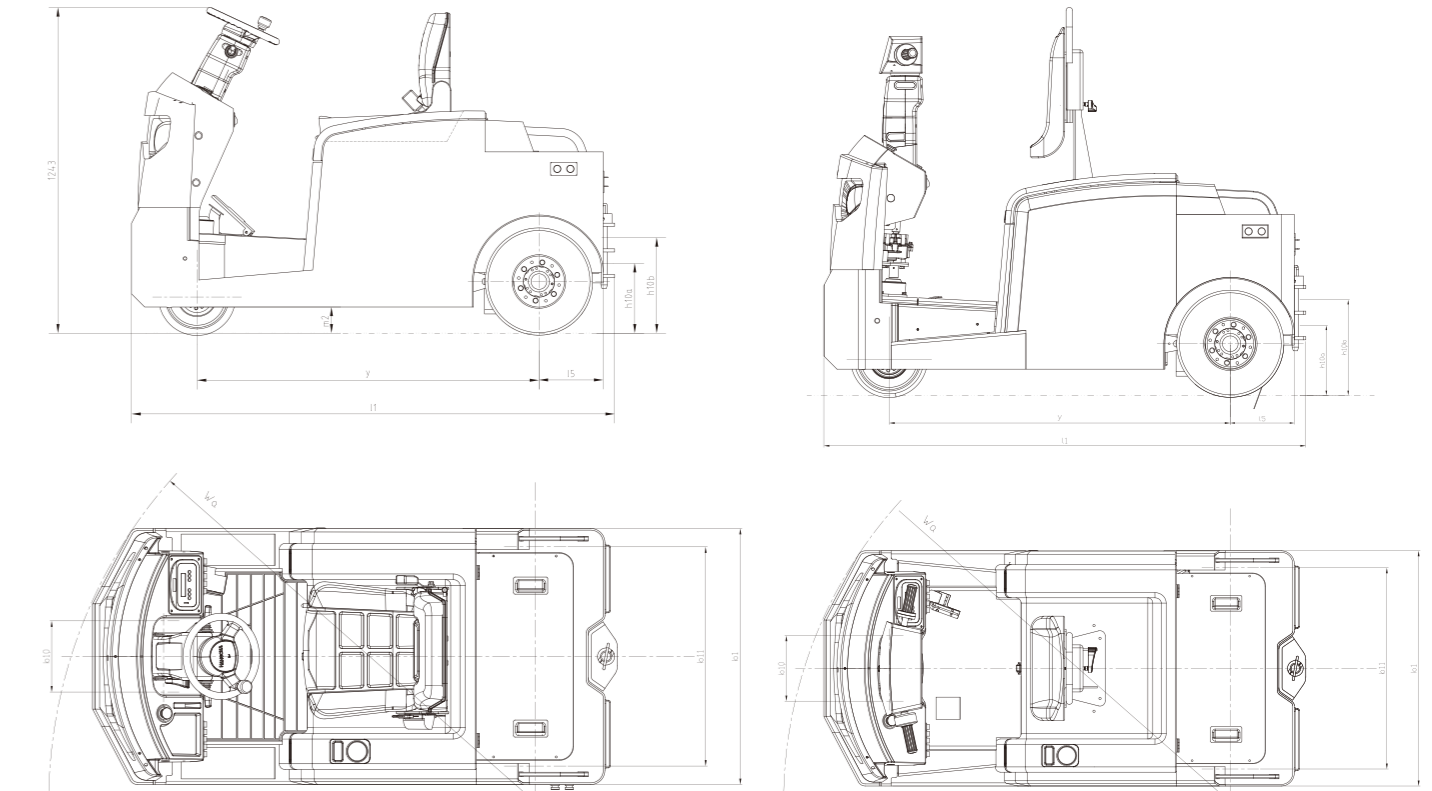

## Maintenance

- / The brushless, maintenance-free AC motor reduces operation cost significantly.
- / The meter integrating battery indicator, timer, and fault self-diagnosis is convenient for maintenance.
- / The front bottom plate and rear cover plate can be easily dismantled, and such parts and components as braking pump, electric control device, motor and so on can be conveniently maintained.

## Options

- / Fully-enclosed driver's cabin
- / Semi-closed cabin
- / Suspension seat (for seating driving type tractor)
- / Reflecting mirror
- / Alarm lamp
- / Solid tyre
- / Big capacity battery